

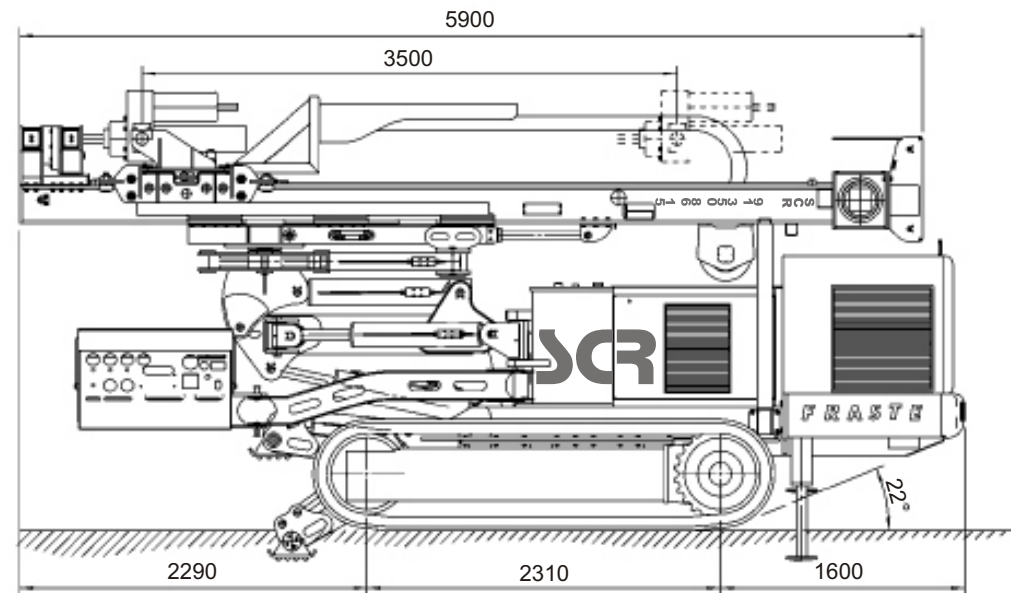

FRASTE MITO 60

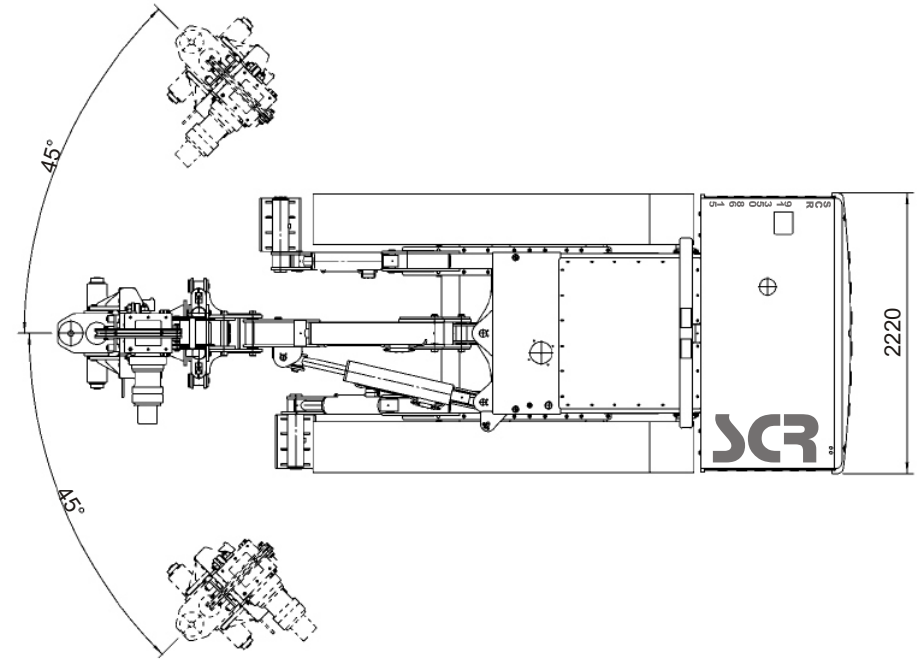

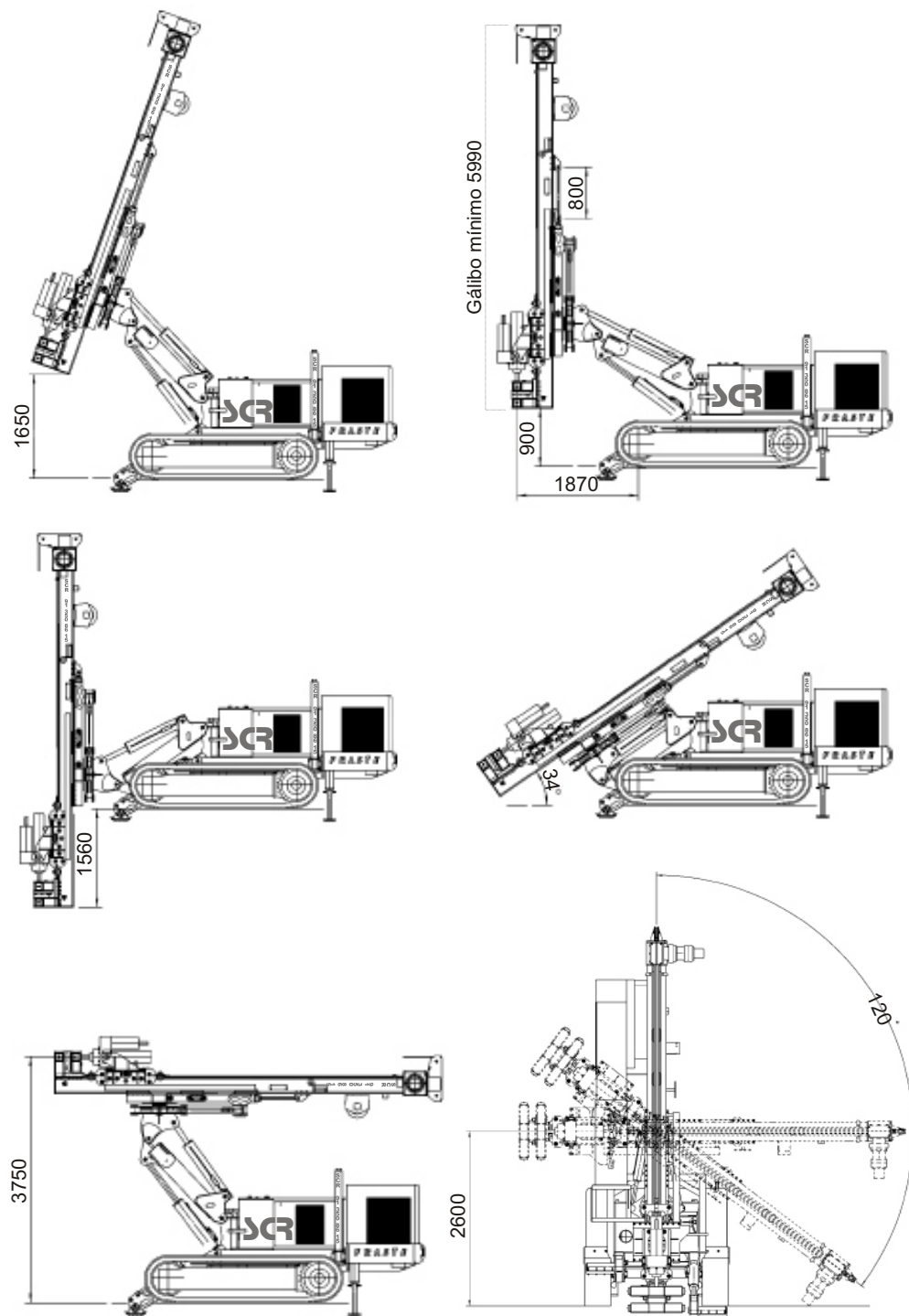

FRASTE MITO 60



CARRO

Peso	12.000 kg
Ancho exterior Orugas	2.220 mm
Distancia entre ejes	2.310 mm
Ancho Patín	450 mm
Gálbo mínimo	5990 mm
Presión suelo	0,65 kg/m ²
Velocidad viaje	3,5 km/h
Máx. pendiente superable	60%

MÁSTIL

Recorrido Barra Rotación	3.500 mm.
Tiro	6.000 daN
Empuje	6.000 daN
Velocidad extracción	40 m/1'
Velocidad avance	40 m/1'

MOTOR

Marca	John Deere
Modelo	4045H275
Potencia	140 cv
Depósito Gasoleo	180 l
Depósito Hidraulico	430 l

MORDAZA

Diámetro Min./Max.	60 - 250 mm
Fuerza Cierre	11.140 daN
Fuerza Giro	1.480 daN

CABRESTANTE

Tiro Max.	2.000 Kg
Diámetro cable	10 mm
Velocidad cable	55 m/1'
Capacidad de cable	30 m



Sondeos Cimentaciones Recalces S.A.
 C/ Puerto de Navafría 11-13
 Pol. Ind. Prado Overa
 28.919.Leganés

Teléfono: 91.350.86.15 Fax: 91.350.47.80
 http://www.scrsa.com email: scr@scrsa.com